

EN

# Tri-Clamp Connectors 3C

## Operating and Installation Instructions

# Contents

<b>1 General information .....</b>	<b>3</b>
1.1 Introduction.....	3
1.2 Warnings .....	3
1.3 Special Hazards .....	3
1.4 General Safety Instructions .....	3
1.5 Designated Use .....	3
1.6 Reasonably Foreseeable Misuse .....	4
<b>2 Manufacturer's Specification .....</b>	<b>4</b>
2.1 Description .....	4
2.2 Transport and Storage.....	4
<b>3 Technical Data .....</b>	<b>4</b>
3.1 Dimensions.....	4
3.2 Operating Medium .....	4
3.3 Pressure Guide .....	4
<b>4 Assembly and Operation .....</b>	<b>5</b>
4.1 Assembly Instructions.....	5
4.2 Tools Required .....	5
4.3 Connect Thread Side .....	5
4.4 Torque Chart.....	5
4.5 Connect Flexible Tube / Pipe Side .....	5
<b>5 Precondition for Commissioning.....</b>	<b>5</b>
<b>6 Maintenance.....</b>	<b>6</b>
<b>7 Disposal .....</b>	<b>6</b>
<b>8 Return Delivery.....</b>	<b>6</b>
<b>9 Troubleshooting / Fault Rectification .....</b>	<b>6</b>
<b>10 Manufacturer's Declaration .....</b>	<b>6</b>
<b>11 Contact.....</b>	<b>6</b>





## 1. General information

### 1.1 Introduction

- These instructions apply to series 3C Tri-Clamp connectors, also referred to below as connectors.
- Read the instructions completely before using our products to prevent injuries, material damage and malfunctions!
- Save the instructions for later reference.
- All rights including copyright and industrial property rights are explicitly reserved.

### 1.2 Warnings

- Warnings are always identified by a signal word. The following signal words or hazard levels are used:

 Danger	<b>Danger:</b> Failure to follow instructions will lead to serious injuries or death. High risk level of endangerment.
 Warning	<b>Warning:</b> Failure to follow instructions may lead to serious injuries or death. Moderate risk level of endangerment.
 Caution	<b>Caution:</b> May lead to slight or moderate injuries. Low risk level of endangerment.
	<b>Note:</b> Refers to an instruction that must absolutely be followed.
	<b>Information:</b> Gives useful tips and recommendations..

### 1.3 Special Hazards

- It must be ensured that the connector is resistant for the media and temperatures that will be used. The resistance of the connector with aggressive media depends in individual cases on many variables (such as the temperature, concentration ratio of the medium, material, environment, tube material etc.). The person ordering the connector is responsible for checking for the specific application. In case of doubt install the connector on a trial basis.
- Always comply with the safety data sheets or the safety requirements for the media you are using!
- Before removing the connector it must be ensured that there is no more medium in the flexible tube system and the pressure has completely dissipated. Exercise caution for toxic, corrosive or hot media residue flowing out of the line or remaining in dead spaces.

### 1.4 General Safety Instructions

- The connector must be properly connected to the flexible tube or pipe system.
- Before installing the connector make certain that external mechanical effects such as thrust and bending forces are not acting on the flexible tube system.
- Installation, commissioning, operation, installation, maintenance, troubleshooting and disassembly must only be performed by qualified specialists with due consideration of accident prevention regulations. Personnel must be capable based on their technical training and experience of performing assembly tasks, following technical specifications and recognizing possible dangers.
- Personnel with deficient knowledge must be trained and instructed.
- Areas of responsibility and responsibilities must be precisely regulated and personnel must be monitored.

These safety instructions do not take into consideration any:

- Coincidences and events that could occur at the customer location during assembly, operation and maintenance.
- Local safety requirements, for which the operating company is responsible to ensure compliance, including assembly personnel who are used.

### 1.5 Designated Use

- The connector must only be operated within the permitted usage ranges for pressure and temperature.
- Only the operating media named in the documentation are permitted to flow through the connector.
- The connector must only be operated if it is in flawless technical condition.
- The connector must not be operated if it is in partially assembled condition.
- If other operating modes are not named in the documentation, they must be approved with the manufacturer.
- A complete, and therefore functional, Tri-Clamp connection consists of two Tri-Clamp flange parts (1&2), a Tri-Clamp flange seal (3) and the Tri-Clamp clamp (4). As there is a wide range of variants for each separate part, these are not usually offered as an assembly but must be purchased individually.

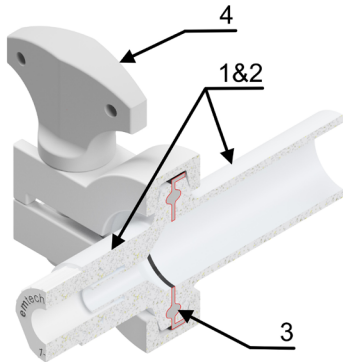

- To ensure proper function, make sure that the individual elements of the Tri-Clamp connection are matched to each other.
- Both Tri-Clamp flanges must have the same size (e.g. TC50.5) and the clamp must be suitable for this size.
- To avoid dead volume, both flange parts and the gasket must have the same internal diameter.

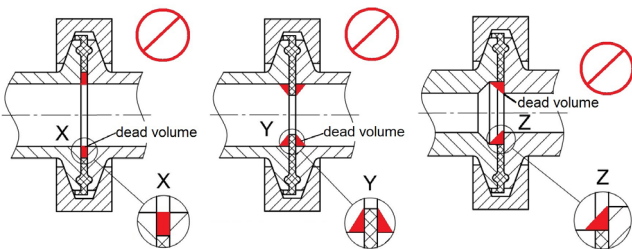
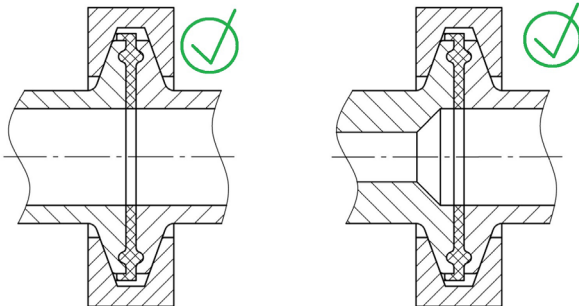

### 1.6 Reasonably Foreseeable Misuse

- Any usage other than designated use.
- Do not make any modifications to the product by yourself!
- Components should only be retrofitted after consultation with the manufacturer.

## 2 Manufacturer's Specification

### 2.1 Description

- The two flange-like connector pieces are press against each other and fastened together using the locking clip. A sealing ring is situated between the connector pieces to maintain a proper seal. The resulting connection is form-fit and smooth and a wing nut on the locking clip makes it easy to quickly open and close the connection at any time.
- The Tri-Clamp connection can be combined with a 1A, 1B, 1C, 1D, 1+, 1B+ or 1W+ flexible tube connector, 2N pipe connector, 3W welding adapter, 3L luer-lock adapter, 3T barb connector or a male or female thread.

### 2.2 Transport and Storage

- The connector must be protected against mechanical damage, moisture, dirt and dust. The storage temperature range is 10 – 40°C.
- Avoid UV radiation and direct sunlight.
- Leave the connector in its original packaging to ensure the best possible protection.
- Dispose of the packaging material according to disposal requirements/environmental protection regulations.



## 3 Technical Data

### 3.1 Dimensions

The exact dimensions of the connector can be found on our homepage under the following link: [www.em-technik.com](http://www.em-technik.com).

Special sizes can be asked via [info@em-technik.com](mailto:info@em-technik.com)



### 3.2 Operating Medium

- Gaseous and liquid media that do not negatively affect the physical and chemical properties of the relevant housing and sealing material.
- If you have questions about resistance please contact **emtechnik**.
- For the maximum permitted operating pressure/temperature see the pressure guide.

### 3.3 Pressure Guide

As the temperature rises, the effectiveness of the connector falls, as shown by this table.

Material	PP	PVDF	PTFE	PFA
Pressure Stage	PN 6	PN 6	PN 6	PN 6
-40°C		75%	75%	75%
-20°C		100%	100%	100%

Material	PP	PVDF	PTFE	PFA
Pressure Stage	PN 6	PN 6	PN 6	PN 6
5°C	100%	100%	100%	100%
20°C	100%	100%	100%	100%
30°C	80%	80%	80%	90%
40°C	70%	70%	70%	85%
50°C	60%	60%	60%	80%
60°C	50%	50%	50%	70%
70°C	40%	45%	40%	60%
80°C	30%	40%	30%	50%
90°C	20%	35%	30%	40%
100°C		35%	30%	40%
110°C		30%	25%	35%
120°C		25%	25%	30%
130°C		25%	25%	30%
140°C		10%	20%	25%

## 4 Assembly and Operation

### 4.1 Assembly Instructions

- Make certain the connector is suitable for the relevant application. The connector must be suitable for the operating conditions of the linesystem (medium, concentration, temperature and pressure) as well as the relevant ambient conditions.
- Check the connector for transport damage before installing it. If the connector is damaged do not install it.
- The planner, the construction company or operating company are responsible for the positioning and installation of the connector. Planning and installation errors can adversely affect the reliable functionality of the connector and may represent a significant potential for hazard.
- After the connector is installed perform a tightness and function check.

### 4.2 Tools Required

The tools required for installation and assembly are not included with delivery.

### 4.3 Connect Thread Side

- The connector must be connected so it is free of mechanical stress.
- The connector can have a male or female thread (ISO,

DIN, ANSI) and can be connected with various connecting elements of the emtechnik system.

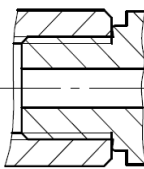
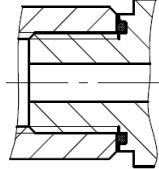
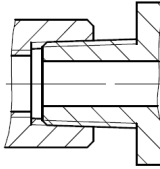
Cylindrical thread	Conical thread	
Sealing is provided by a sealing collar for Cylindrical threads (G, M or UNF). A version with an O-ring is also possible.	Sealing is provided by the thread itself for Conical threads (NPT).	
Sealing Collar	O-Ring	Thread
		

- Each thread must always be connected with the same thread type.
- If a plastic connector is used in combination with a metallic male fitting, additional sealing with Teflon® tape is recommended.

### 4.4 Tightening torques for G-thread

Plastic	Thread				
	G 1/8"	G 1/4"	G 3/8"	G 1/2"	G 3/4"
PP	1,0 Nm	1,5 Nm	4,0 Nm	4,0 Nm	4,0 Nm
PVDF	1,0 Nm	1,5 Nm	4,0 Nm	4,0 Nm	4,0 Nm
PFA	0,3 Nm	0,5 Nm	1,0 Nm	2,5 Nm	5,0 Nm
PTFE	0,3 Nm	0,5 Nm	1,0 Nm	2,5 Nm	5,0 Nm

All data in Nm

### 4.5 Connect Flexible Tube / Pipe Side

- The Tri-Clamp 3C has a 1+, 1A or 1C tube connection, a 3L luer lock adapter, a 2N tube connection, or a barb connection.
- For the instructions of the tube or pipe fitting, please refer to the instructions corresponding to the connection principle at [em-technik.com/en/service/assembly-guides](http://em-technik.com/en/service/assembly-guides)

## 5 Precondition for Commissioning

- Protect against leaks: Take protective measures against exceeding the maximum permitted pressure due to possible pressure surges.
- Check the tightness and function of the connector.
- In new systems and after repairs, flush the line system to remove foreign materials.

## 6 Maintenance

- When used as designated, the connector is practically wear-free and generally requires no maintenance.
- The operating company must perform regular visual inspections of the connector according to the operating conditions to prevent leaks and damage.

## 7 Disposal

- When disposing of the connector and packaging, comply with the relevant disposal requirements and environmental protection regulations.
- When disposing of connector, pay careful attention to any residues of toxic or corrosive media.



Warning

## 8 Return Delivery



Do not return before consulting with **emtechnik**.

1. Please consult with **emtechnik**.
2. Empty the connector properly.
3. Rinse and clean the connector thoroughly, especially if the media is being conveyed are harmful, explosive, hot, or hazardous in some other way.
4. For connectors that have been operated with aggressive, corrosive, combustible, toxic or water polluting media, a completely filled in clearance certificate must always be included.

## 9 Troubleshooting / Fault Rectification

Error	Possible Cause	Error Rectification
Connection between thread side and system leaking	Sealing surface is damaged	Use sealant, see 4.3
Flexible tube connection is leaking	Flexible tube is not correct mounted	Mount connector correctly and secure with a pipe clamp.
No flow	Connector is blocked	Clean the connector or replace it if necessary
Leaking between two flanges	Seal does not fit	Use the correct seal
Leaking between two flanges	Closure clamp is not correctly selected or not correctly tightened	Replacing of the locking clamp or tightening of the sash cap on the clamp

## 10 Manufacturer's Declaration

- Our products do not fall under the scope of the Machinery Directive 2006/42/EC. However, they can be incorporated in an installation that is considered as machinery. In this case regard the following note: The products may not be put into operation until it is made sure that the final machinery into which our products are incorporated complies with the provisions of the Machinery Directive 2006/42/EC.
- Based on the fluid class, pressure and nominal diameter, our products fall under diagram 8 of the Pressure Equipment Directive PED 2014/68/EU. Because of the ratio of nominal diameter, pressure and volume, they fall only under article 4 paragraph 3 and are designed and manufactured according to applicable good engineering practice. They must not carry any CE marking.
- The warranty of armature expires in the following cases: Operating conditions which do not follow the intended use or do not follow technical specifications. Improper installation or assembly. Just as well as inappropriate use, dismantling or modification.
- Failure to observe information provided here may lead to injuries, material damage, malfunctions and impurities due to escaping medium.



Warning

## 11 Contact

If you have questions or suggestions please contact us at:

### EM-Technik GmbH

Industriestr. 2  
67133 Maxdorf  
Germany

Tel +49 6237 407-0  
Fax +49 6237 407-77  
info@em-technik.com